

# ICC-ES Evaluation Report

**ESR-1319\***

Reissued October 1, 2008

This report is subject to re-examination in two years.

[www.icc-es.org](http://www.icc-es.org) | (800) 423-6587 | (562) 699-0543

A Subsidiary of the International Code Council®

**DIVISION: 04—MASONRY**  
**Section: 04810—Unit Masonry Assemblies**

**REPORT HOLDER:**

**ALLIANCE CONCRETE CONCEPTS, INCORPORATED**  
 325 ALLIANCE PLACE N.E.  
 ROCHESTER, MINNESOTA 55906  
 (507) 529-2879  
[www.moderra.com](http://www.moderra.com)

**EVALUATION SUBJECT:**
**MODERRA CONCRETE SIDING**
**1.0 EVALUATION SCOPE**
**Compliance with the following codes:**

- 2006 *International Building Code*® (IBC)
- 2006 *International Residential Code*® (IRC)

**Properties evaluated:**

- Weather resistance
- Transverse wind load resistance

**2.0 USES**

Moderra Concrete Siding is a mortarless, nonstructural, concrete veneer mechanically fastened to the wood stud structural framing of buildings to provide weather protection as part of an approved building envelope. The dead load of the concrete veneer units is supported at the base of the wall by either a brick ledge, timber ledge or steel angle.

**3.0 DESCRIPTION**
**3.1 General:**

The Moderra Concrete Siding system is a mortarless, nonstructural, nonload-bearing, concrete veneer consisting of concrete block units and aluminum extrusions. The concrete veneer is attached to exterior walls using H-channel aluminum extrusions installed vertically. The concrete veneer units have grooves that are designed to fit the H-channel flanges. The H-channels provide transverse load resistance for the veneer. The dead load for the veneer is transferred to the base of the wall and supported on either a brick ledge, timber ledge or steel angle.

Use of the veneer is limited to Type V-B, nonfire-resistance-rated, building construction under the IBC and construction in accordance with the IRC.

**3.2 Materials:**

**3.2.1 Moderra Concrete Block Units:** The Moderra Concrete Siding block units are concrete masonry units conforming to ASTM C 55 as Grade N, solid concrete units, except:

The net minimum compressive strength is 2300 psi (16 MPa).

The maximum water absorption is 7 percent.

The minimum face shell and web thicknesses are not applicable, since the units have a proprietary shape.

Refer to Figure 1 for block unit dimensions. The Moderra block units are available in four shapes as follows:

**Standard Block:** Nominally 8 inches high by 16 inches wide by 2<sup>1</sup>/<sub>2</sub> inches deep (203.2 mm high by 406.4 mm wide by 63.5 mm deep) and weighing 25 pounds (12.4 kg). The surface area is 0.889 square foot (0.08 m<sup>2</sup>).

**Four-inch Block:** Nominally 4 inches high by 16 inches wide by 2<sup>1</sup>/<sub>2</sub> inches deep (101.6 mm high by 406.4 mm wide by 63.5 mm deep) and weighing 12 pounds (6 kg). The surface area is 0.445 square foot (0.04 m<sup>2</sup>). The installed weight of the wall system is 28 pounds per square foot (1344 Pa).

**Corner Block:** Nominally 8 inches high by 8 inches wide on each leg and 2<sup>1</sup>/<sub>2</sub> inches deep (203.2 mm high by 203.2 mm wide on each leg and 63.5 mm deep), and weighing 22 pounds (11 kg). The total surface area is 0.889 square foot (0.08 m<sup>2</sup>).

**Sill Block:** Nominally 4 inches high by 16 inches wide by 4<sup>1</sup>/<sub>2</sub> inches deep (101.6 mm high by 406.4 mm wide by 114.3 mm deep), and weighing 18 pounds (9 kg). The surface area is 0.445 square foot (0.04 m<sup>2</sup>).

**3.2.2 Moderra Inside H-Channel, Outside H-Channel and Trim-Channel Aluminum Extrusions:** The aluminum extrusions are 6063-T6 alloy complying with ASTM B 221. The extrusions are supplied in standard lengths of 8 feet (2.4 m). Dimensional drawings of the aluminum extrusions are shown in Figure 1.

**3.2.3 Fasteners:** Fasteners used to attach the H-channels and Trim-Channels to wood structural panels must be No. 8, corrosion-resistant wood screws, a minimum of 1<sup>1</sup>/<sub>2</sub> inches (38.1 mm) long with 1/4-inch (6.35 mm) hex heads.

**3.2.4 Water-resistive Barrier:** The Moderra Concrete Siding system must be installed over a water-resistive barrier complying with IBC Section 1404.2 or IRC Section R703.2 as applicable.

**4.0 INSTALLATION AND DESIGN**
**4.1 Installation:**

**4.1.1 General:** Moderra Concrete Siding must be installed in accordance with IBC Section 1405.5 or IRC Section R703.7, as applicable. Additionally, installation must comply with Sections 6.1 and 6.2 of the Building Code Requirements for Masonry Structures, ACI

\*Revised November 2009

530/ASCE 5/TMS 402, this evaluation report, and the manufacturer's published installation instructions. Refer to Figure 2 for typical wall details. A water-resistive barrier complying with Section 3.2.4 must be installed over the wood structural panels.

Expansion or control joints must be provided to limit the effect of differential movement of supports and must be specified on the approved plans by a registered design professional or the veneer manufacturer, in that order. Consideration must be given to movement caused by temperature changes, creep and deflection.

**4.1.2 Installation over Wood Structural Panels:** The Moderra Concrete Siding system must be installed over wood structural panels complying with DOC PS 2 with a minimum thickness of  $7/16$  inch (11.11 mm) and a span rating of 24/16. Studs must be spaced 16 inches (406 mm) on center and must be minimum nominally 2-by-4, No. 2 SPF with a minimum specific gravity of 0.42. Typical installation must start with an Outside H-channel installed vertically and located a distance of 8 inches (203.2 mm) from the corner, and attached through the wood structural panels into the wood stud with fasteners described in Section 3.2.3 spaced 24 inches (609.6 mm) on center. Fasteners must penetrate through the wood structural panel sheathing into the wood studs. The block units must then be installed by sliding the block units into the channels using the grooves on the blocks. The Inside H-channel extrusions must then be installed vertically and fitted into the block unit grooves and attached through the wood structural panels into wood studs with fasteners described in Section 3.2.3 spaced 24 inches (609.6 mm) on center. The aluminum extrusions are installed vertically for the full height of the concrete veneer wall. Installation of outside and inside corners, doors and windows and coping and flashing are included in the manufacturer's published installation instructions.

## 4.2 Design:

**4.2.1 Design in Accordance with the IBC:** Calculations and plans must be submitted to the code official for approval. The calculations must be prepared by a registered design professional where required by the statutes of the jurisdiction in which the project is to be constructed. The calculations must verify that the structural framing or wall substrate, lintels, connectors, and fasteners supporting the veneer are adequate to resist the allowable design wind pressure loads imposed by the veneer, as noted in Section 4.2.3. The dead load for the concrete veneer is transferred to the base of the wall and supported on either a brick ledge, timber ledge or steel angle. Calculations must be provided verifying that these structural members are adequate to resist the vertical dead load of the concrete veneer. Veneer dead load supported on wood members must be installed in accordance with Section 2304.12 of the IBC. Support requirements and related conditions must comply with Section 6.2.2.3 of ACI 530/ASCE 5/TMS 402.

The concrete veneer must only be installed in areas designated as Seismic Design Category A, B or C. In areas designated as Seismic Design Category C, fastener design and installation requirements must comply with Section 1405.5 of the IBC and Section 6.2.2.10.1 of ACI 530/ASCE 5/TMS 402. The concrete veneer must only be installed in areas with a wind speed of less than 110 mph (3-second gust) in accordance with Section 6.2.2.1 of ACI 530/ASCE 5/TMS 402.

**4.2.2 Design in Accordance with the IRC:** Calculations and plans must be submitted to the code official for approval. The calculations must be prepared by a registered design professional where required by the statutes of the jurisdiction in which the project is to be constructed. The calculations shall verify that the structural

framing or wall substrate, lintels, connectors, and fasteners supporting the veneer are adequate to resist the allowable design wind pressure loads imposed by the veneer, as noted in Section 4.2.3. The dead load for the concrete veneer is transferred to the base of the wall and supported on either a brick ledge, timber ledge or steel angle. Calculations must be provided verifying that these structural members are adequate to resist the vertical dead load of the concrete veneer. Veneer dead load supported on wood members must be installed in accordance with Section R703.7.2.

The concrete veneer must only be installed in areas designated as Seismic Design Category A, B, C, D<sub>0</sub>, D<sub>1</sub>, and D<sub>2</sub>. Buildings constructed with the Moderra Concrete Siding system and designed in accordance with this section are subject to the wall bracing and height limitations noted in IRC Sections R301.2.2.3 and R703.7.

**4.2.3 Maximum Allowable Design Wind Pressure:** Installation of the Moderra Concrete Siding must be limited to areas where the design transverse wind pressure, as calculated in accordance with Section 1609 of the IBC or Section R301.2.1 of the IRC, for components and cladding, does not exceed 27 lbf/ft<sup>2</sup> (1.3 kPa). The concrete veneer must only be installed in areas with a wind speed of less than 110 mph (3-second gust) in accordance with Section 6.2.2.1 of ACI 530/ASCE 5/TMS 402.

## 5.0 CONDITIONS OF USE

The Moderra Concrete Siding system described in this report complies with, or is a suitable alternative to what is specified in, those codes listed in Section 1.0 of this report, subject to the following conditions:

- 5.1 The materials, fabrication and installation must comply with this report and the manufacturer's instructions.
- 5.2 For design in accordance with the IBC, refer to Section 4.2.1.
- 5.3 For design in accordance with the IRC, refer to Section 4.2.2.
- 5.4 Transverse wind pressures must be in accordance with Section 4.2.3.
- 5.5 Use of the veneer is limited to Type V-B, nonfire-resistance-rated, building construction under the IBC and construction in accordance with the IRC.
- 5.6 Substrates over which the veneer is installed must be flat and solid and must comply with the applicable provisions of the IBC or IRC and must be capable of supporting the transverse loads imposed by the veneer.

## 6.0 EVIDENCE SUBMITTED

- 6.1 Test report on transverse load testing of wall assemblies in accordance with ASTM E 330.
- 6.2 Test report on strength testing of stone anchorages in accordance with ASTM C 1354.
- 6.3 Test report on physical properties under ASTM C 55; compressive strength under ASTM C 140; flexural strength under ASTM C 99; density under ASTM C 140; absorption under ASTM C 140; and freeze-thaw under ASTM C 67.
- 6.4 Quality documentation.

## 7.0 IDENTIFICATION

Individual block units and aluminum extrusions must be identified by their unique shapes (refer to Figures 1 and 2). Pallets of the block units and packages of the aluminum extrusions must be labeled with the evaluation report number (ESR-1319), the name of the manufacturer (Rochester Concrete Products, LLC) and the product name (Moderra Concrete Siding).

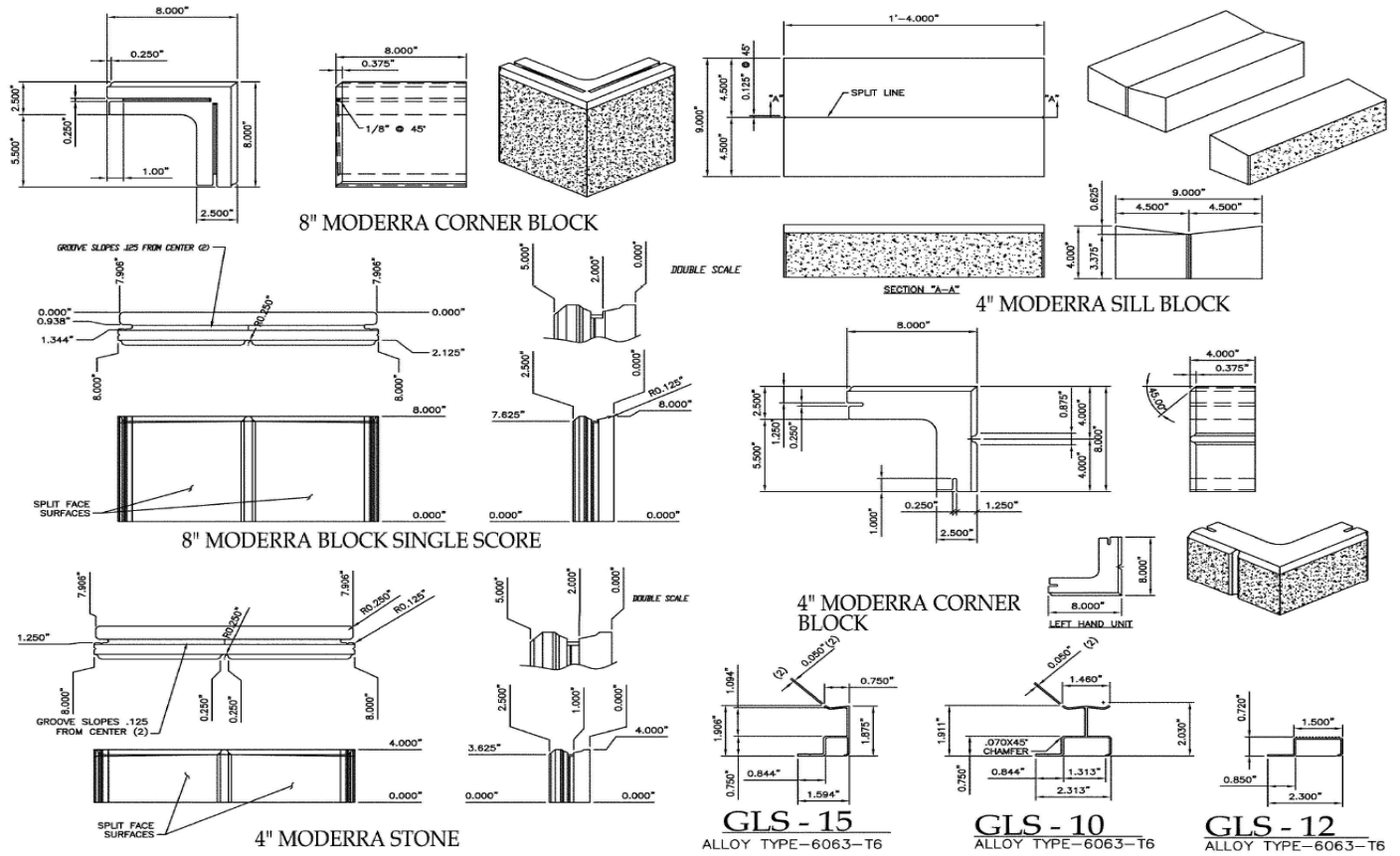

FIGURE 1—MODERRA CONCRETE BLOCK UNITS, ALUMINUM EXTRUSIONS AND TYPICAL WALL DETAILS

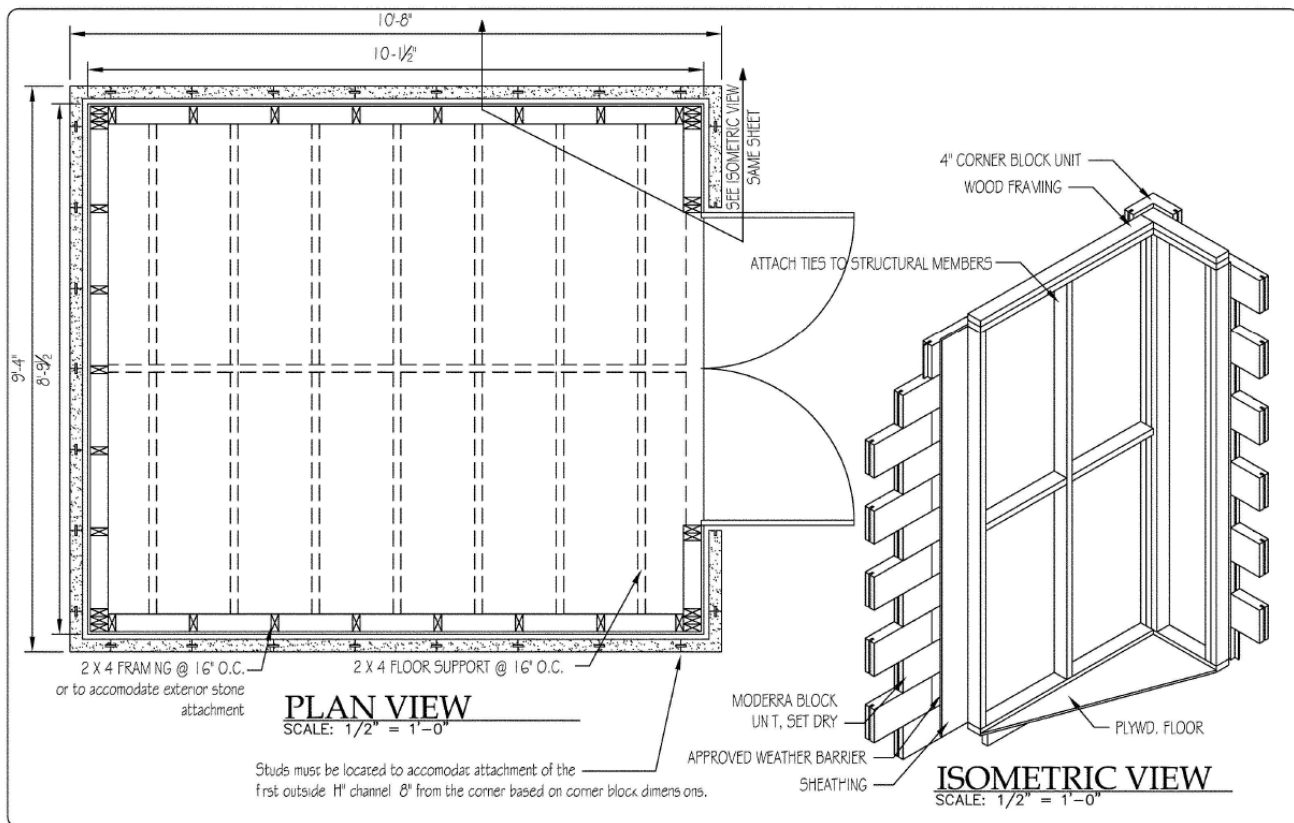

FIGURE 2—MODERRA CONCRETE BLOCK UNITS, TYPICAL WALL DETAILS